

 **HAWKER**
ARMASAFE
plus



NBB 248

MAINTENANCE FREE COMBAT AND TACTICAL VEHICLE BATTERY

RIPEnergy[®]

The power conversion company



HAWKER ARMASAFE *plus* NBB 248



- Sealed for life
- Long shelf life
- High engine starting capability
- Supplied filled and charged
- Recovers from deep discharge
- Exceptional charge acceptance
- Robust - shock/vibration
- Fully air transportable
- UN 2800 Class 8 exempt

NSN 6140-12-190-9027
HAWKER P/N: 9750N7018

ARMASAFE *plus* is currently installed in Military vehicles throughout the world. Based on Hawker's recombination technology, the battery provides maximum performance with minimum maintenance.

ARMASAFE *plus* NBB 248 is approved to VG 96924 T 09 specification.

ARMASAFE *plus* is the battery to keep the army on the move.

TECHNICAL DETAILS

Nominal Voltage	12 Volts
Charging Voltage	14.25± 0.25V
Nominal Capacity	100Ah (C ₅)
Operating Temperature	Continuous -30°C to +40°C Intermittent -40°C to +55°C
Storage	2 years ≤ 20°C (without recharge)
Weight (max)	39.5Kg
CCA (S.A.E)	1050A
Terminals to DIN 72 311 Part 4	

RECHARGE from 50% Depth of Discharge VG 96 924 T02

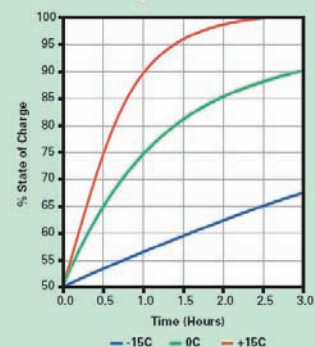

500A DISCHARGE VG 96 924 T02

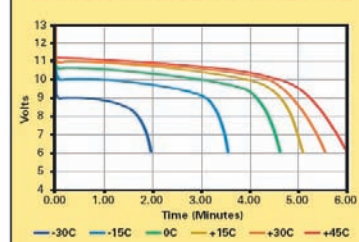

DIMENSIONS

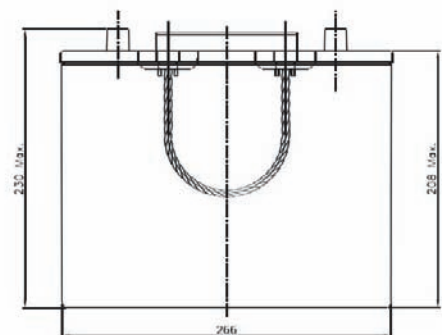
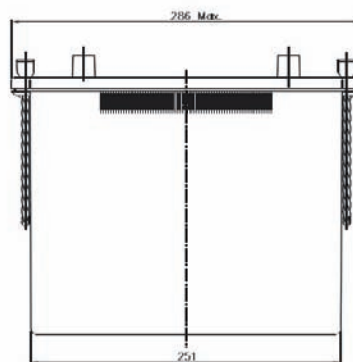
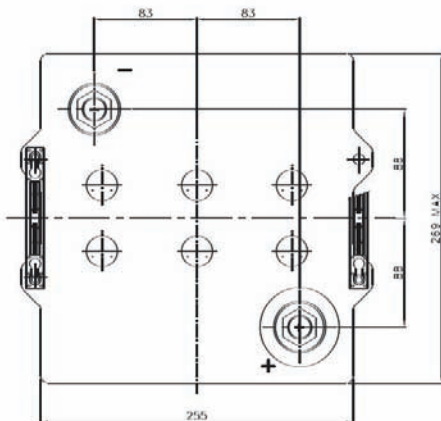

Available from:

RIPEnergy

The power conversion company

RIPEnergy AG
Wägitalstrasse 24
CH-8854 Siebnen
Switzerland

Ph +41-(0)43-818 53 85
Fax +41-(0)43-818 53 87
www.ripenergy.ch

